



# DTM Series Diversity Systems

## User Manual



### Order codes:

**MIC70 - DTM 800H 863.0Mhz-865.0Mhz**

**MIC72 - DTM 600H 606.0Mhz-614.0Mhz**

**MIC70A - DTM 800 863.0Mhz-865.0Mhz**

**MIC72A - DTM 600 606.0Mhz-614.0Mhz**

## WARNING

### FOR YOUR OWN SAFETY, PLEASE READ THIS USER MANUAL CAREFULLY BEFORE YOUR INITIAL START-UP!

- Before your initial start-up, please make sure that there is no damage caused during transportation.
- Should there be any damage, consult your dealer and do not use the equipment.
- To maintain the equipment in good working condition and to ensure safe operation, it is necessary for the user to follow the safety instructions and warning notes written in this manual.
- Please note that damages caused by user modifications to this equipment are not subject to warranty.



#### IMPORTANT:

The manufacturer will not accept liability for any resulting damages caused by the non-observance of this manual or any unauthorised modification to the equipment.

- Never let the power cable come into contact with other cables. Handle the power cable and all mains voltage connections with particular caution!
- Never remove warning or informative labels from the unit.
- Do not open the equipment and do not modify the unit.
- Do not connect this equipment to a dimmer pack.
- Do not switch the equipment on and off in short intervals, as this will reduce the system's life.
- Only use the equipment indoors.
- Do not expose to flammable sources, liquids or gases.
- Always disconnect the power from the mains when equipment is not in use or before cleaning! Only handle the power-cable by the plug. Never pull out the plug by pulling the power-cable.
- Make sure that the available voltage 9V DC, 1500mA. (240V AC~50Hz power supply included)
- Make sure that the power cable is never crimped or damaged. Check the equipment and the power cable periodically.
- If the equipment is dropped or damaged, disconnect the mains power supply immediately and have a qualified engineer inspect the equipment before operating again.
- If the equipment has been exposed to drastic temperature fluctuation (e.g. after transportation), do not connect power or switch it on immediately. The arising condensation might damage the equipment. Leave the equipment switched off until it has reached room temperature.
- If your product fails to function correctly, stop use immediately. Pack the unit securely (preferably in the original packing material), and return it to your Pro Light dealer for service.
- Only use fuses of same type and rating.
- Repairs, servicing and power connection must only be carried out by a qualified technician. **THIS UNIT CONTAINS NO USER SERVICEABLE PARTS.**
- This fixture is for professional use only - it is not designed for or suitable for household use. The product must be installed by a qualified technician in accordance with local territory regulations. The safety of the installation is the responsibility of the installer. The fixture presents risks of severe injury or death due to fire hazards, electric shock and falls.
- **WARRANTY:** One year from date of purchase.

#### OPERATING DETERMINATIONS

If this equipment is operated in any other way, than those described in this manual, the product may suffer damage and the warranty becomes void. Incorrect operation may lead to danger e.g: short-circuit, burns and electric shocks etc.

In case of malfunction this unit should be returned for service or inspection.

Do not endanger your own safety and the safety of others!

Incorrect installation or use can cause serious damage to people and/or property.

## DTM Series Diversity Systems

DTM series wireless microphones feature twin UHF belt pack or handheld systems with 20 (863-865Mhz) or 80 (606-614Mhz) selectable frequencies. Available in either Channel 38 (606-614Mhz) for the DTM600 or Channel 70 (863-865Mhz) for the DTM800; both systems utilise a true diversity, full bandwidth receiver for the ultimate in RF stability. Outstanding vocal reproduction and stable wireless connectivity allow freedom of movement on stage. These systems offer crystal clear sound reproduction and rock solid reliability. Metal bodied transmitters feature ergonomic design with a rugged housing to stand up to the rigours of the road. Supplied with a foam lined carry case for protection during transit. The flexibility of the handheld systems may be increased by purchasing the additional DTM 600BP.

- Phase Lock Loop (PLL)
- IR sync facility for simple setup
- True diversity receiver
- 863-865Mhz - 20 frequencies or 606-614Mhz - 80 frequencies
- Large LCD receiver display including RF level, AF level, channel and frequency
- LCD transmitter display
- Auto frequency scanning
- Balanced XLR output for each channel plus unbalanced mixed output
- Frequency response (handheld): 40Hz-15kHz
- Transmitter battery configuration: 2 x 1.5V AA (not supplied)
- Audio output level: 400mV
- Dynamic range: 96dB
- Receiver power supply: 9V DC (mains adaptor supplied)
- 1U full width rack mount receiver



Specifications	DTM 800H Twin Handheld Diversity System	DTM 600H Twin Handheld Diversity System	DTM 800 Twin Beltpack Diversity System	DTM 600 Twin Beltpack Diversity System
Operating frequency	863.0Mhz-865.0Mhz	606.0Mhz-614.0Mhz	863.0Mhz-865.0Mhz	606.0Mhz-614.0Mhz
Power supply	DC 9V, 1500mA (adaptor supplied)		DC 9V, 1500mA (adaptor supplied)	
Order code	MIC70	MIC72	MIC70A	MIC72A

In the handheld system box:  
**1 x receiver, 2 x wireless microphones, 1 x PSU, 1 x audio lead & 1 x user manual**

In the beltpack box:  
**1 x receiver, 2 x beltpacks, 1 x headset microphone, 1 x lavalier microphone, 1 x PSU, 1 x audio lead & 1 x user manual**

## Receiver front panel identification:

### 1. Power Switch

On/Off control for the system receiver

### 2. Volume Control – Channel A

The receiver's output volume is adjustable. Turn the level control anti clockwise to the lowest setting, or turn clockwise to adjust to the highest setting. Each channel features an independent volume control.

### 3. IR Transceiver

The IR transceiver is used to communicate with the systems transmitters during setup.

### 4. Up Button – Channel A

### 5. Set Button – Channel A

### 6. Down Button – Channel A

### 7. Display

The receiver features a backlit display allowing the user to see information about the receiver including frequency, channels, mute status, audio, RF status and battery level.

### 8. Down Button – Channel B

### 9. Set Button – Channel B

### 10. Up Button – Channel B

### 11. Volume Control – Channel B

The receiver's output volume is adjustable. Turn the level control anti clockwise to the lowest setting, or turn clockwise to adjust to the highest setting. Each channel features an independent volume control.

## Receiver rear panel identification:

### 12. Antenna – Channel A

The antenna receives the RF radio signal from the transmitter unit. For optimum reception, orientate vertically. Reception may be impaired by obstacles between the transmitter and receiver. High power electrical equipment can cause unwanted interference.

### 13. Balanced Audio Output B

Individual, balanced audio outputs via 3 pin XLR for audio channel B.

### 14. Balanced Audio Output A

Individual, balanced audio outputs via 3 pin XLR for audio channel A.

### 15. Audio (MIX) Output

6.35mm (1/4") jack socket outputting an unbalanced, line level audio output featuring both audio channels.

### 16. DC Power Input

The receiver is powered by a standard DC power input 9V DC, 1500mA regulated voltage supply.

### 17. Antenna – Channel B

The antenna receives the RF radio signal from the transmitter unit. For optimum reception, orientate vertically. Reception may be impaired by obstacles between the transmitter and receiver. High power electrical equipment can cause unwanted interference.

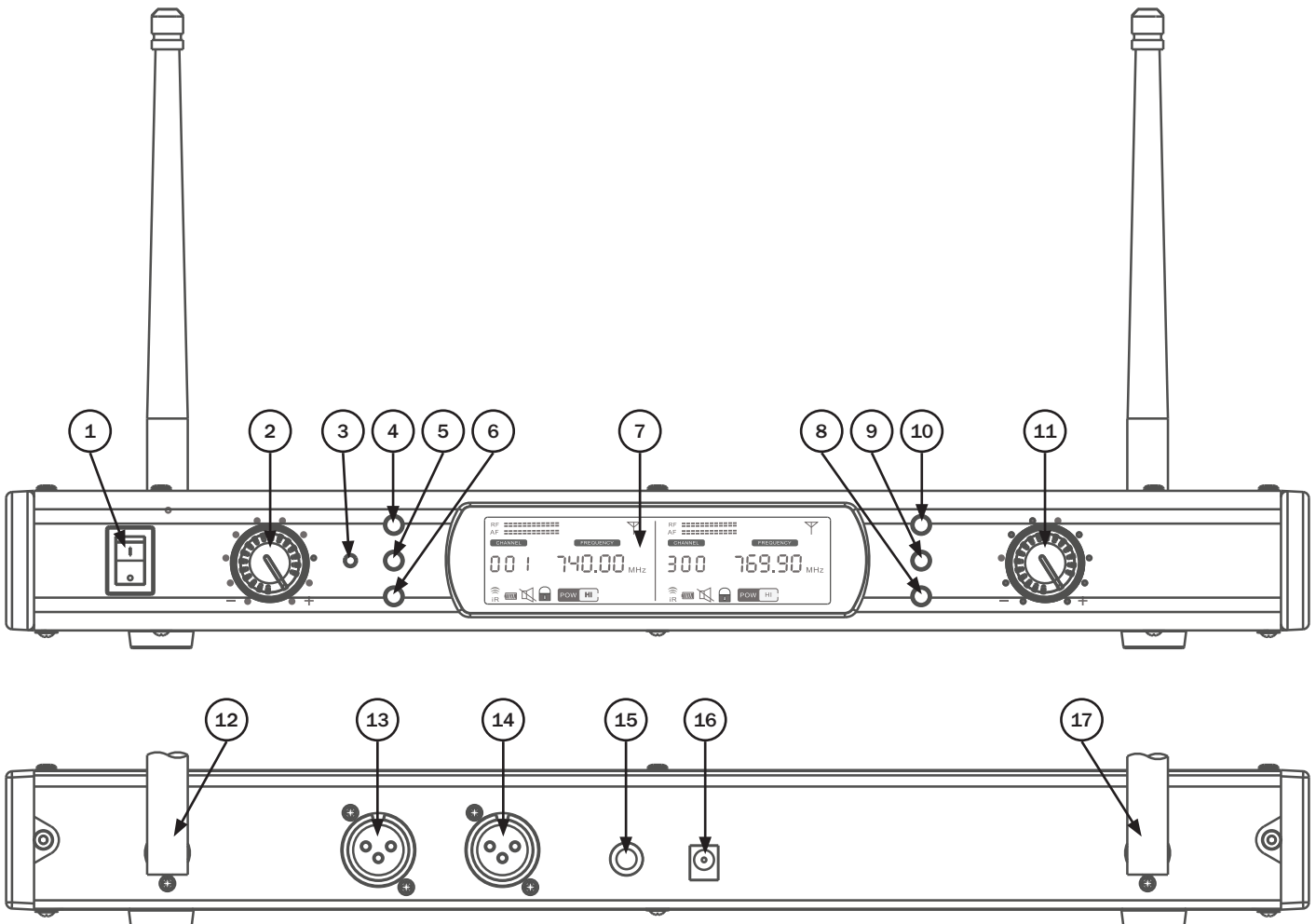

## Display Identification:

### 1. RF Level RF ██████

The RF level indicator is a visual representation of the radio frequency signal strength utilising a 10 segment bar graph. As the radio signal received is reduced, the bar graph will reduce.

### 2. AF Level AF ██████

The AF level indicator is a visual representation of the audio signal strength utilising a 10 segment bar graph. As the audio signal fluctuates bar graph will indicate this.

### 3. Channel indicator CHANNEL 001

Displays the current RF channel in use by the transmitter/receiver.

### 4. Frequency 740.00 Mhz

Displays the current RF frequency in use by the transmitter/receiver.

### 5. Battery Level ██████

The receiver displays the current battery level in the transmitters allowing remote monitoring of the transmitters battery level.

### 6. IR Sync

During synchronisation, the IR Sync will flash a radiating symbol.

### 7. Lock

The receiver features a lock function to prevent accidental changes to the settings. Press and hold LOCK to unlock the menu system. After a short period of inactivity, the display will automatically lock.

### 8. Hi/Lo transmit power POW HI

The user may select the RF transmission power from the menu system. When used in close proximity, the transmitters should be set to Lo or over greater distances, set to Hi.

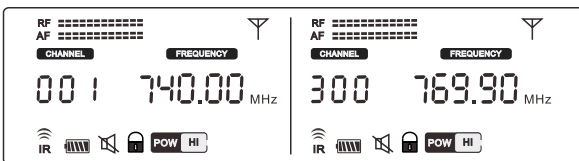

## Operation:

- Carefully, lift the antennae into the vertical position.
- Connect the included power supply to a suitable 240V AC~50Hz mains voltage outlet and plug the DC connector into the DC. Power Input on the rear panel of the receiver (9V DC, 1500mA minimum).
- Using the supplied audio cable, connect the MIX OUT on the rear panel of the receiver for both audio channels to the mixer's audio line input. The receiver also features balanced XLR outputs, one for each channel.
- Switch on the power to the receiver, checking the display backlight illuminates.
- Open the battery compartment on the transmitter (Beltpack – slide downwards away from the belt clip. Handheld - unscrew the lower portion). Install the appropriate batteries into the transmitter, taking care to observe the orientation and polarity. Only use high quality, alkaline type batteries. Refit the battery compartment cover carefully.
- Switch on the transmitter, when switched on the display on the transmitter will illuminate. If the display does illuminate or glows dimly, the battery will require replacement.
- Adjust the volume on the front panel of the receiver for each of the channels.
- Follow the IR Sync Operation fully to ensure the transmitters are linked correctly to the receiver unit. Failure to follow this fully will prevent the microphone system from operating correctly.
- Channel (Frequency) Setup:  
Press and hold the SET button to unlock the menu function. The CHANNEL mode will flash, use the UP/DOWN buttons to select the desired channel, the frequency will automatically change. The DTM 800 has 20 available channels within the 863-865Mhz range, where as the DTM 600 has 80 available within the 606-614Mhz range. After changing the channel, the IR sync must be carried out to ensure the transmitter is matched for correct operation.

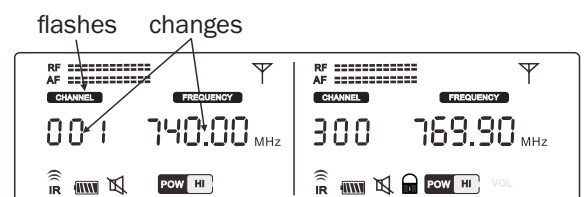

## Operation continued:

- Frequency Scan Mode:

To allow the user to select a frequency free from interference, the receiver features a frequency scan mode. Firstly, switch on any transmitters from other systems in the vicinity. Press and hold the SET button to unlock the menu function and then press SET until the display shows a rectangle underneath the frequency header. Use the Up or Down keys to commence scanning. The receiver will stop scanning when it reaches the first available frequency. Further scanning can be triggered by pressing the up/down button again. After changing the frequency, the IR sync must be carried out to ensure the transmitter is matched for correct operation.

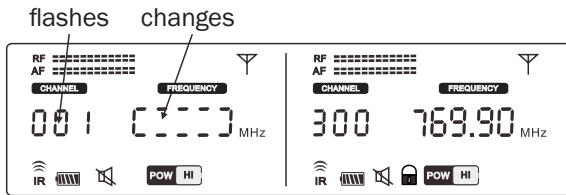

- Transmitter Power Mode:

The user may select the RF transmission power from the menu system. When used in close proximity, the transmitters should be set to Lo or over greater distances, set to Hi. Press and hold the SET button to unlock the menu function, then press the SET button twice more until the POW selection flashes. Press the SET button to confirm selection. After changing the power setting, the IR sync must be carried out to ensure the transmitter is matched for correct operation.

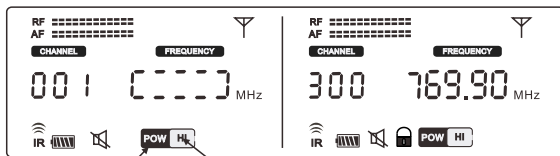

When the POW is flashing, the HI can be adjusted to LO

- IR Sync Operation:

After making changes to the settings on the receiver, the IR Sync operation should be carried out to ensure the settings are replicated into the transmitter to ensure correct operation.

Power on both the transmitter and receiver, cycle thru the menu system on the receiver until all settings are correct. Press and hold the SET button to trigger the IR Sync operation. The IR Sync indicator will show the radiating symbol, while the radiating symbol is flashing, direct the display on the relevant transmitter towards the IR Transceiver, the transmitter will then change to match the settings on the receiver. The microphone is now ready for use. Note: The beltpack transmitter IR Transceiver is located inside the battery compartment.

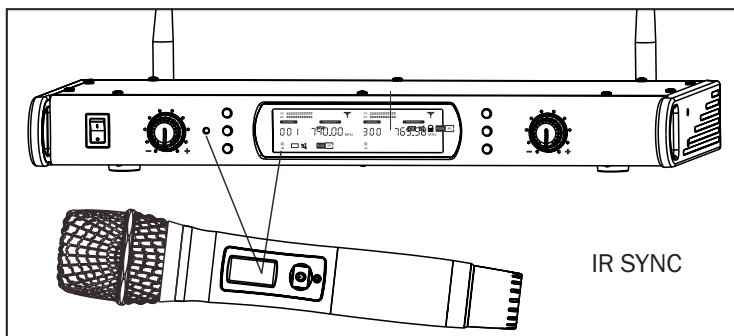

## Handheld transmitter identification:

1. Grille
2. LCD Display
3. IR Transceiver
4. Power Switch
5. Battery compartment

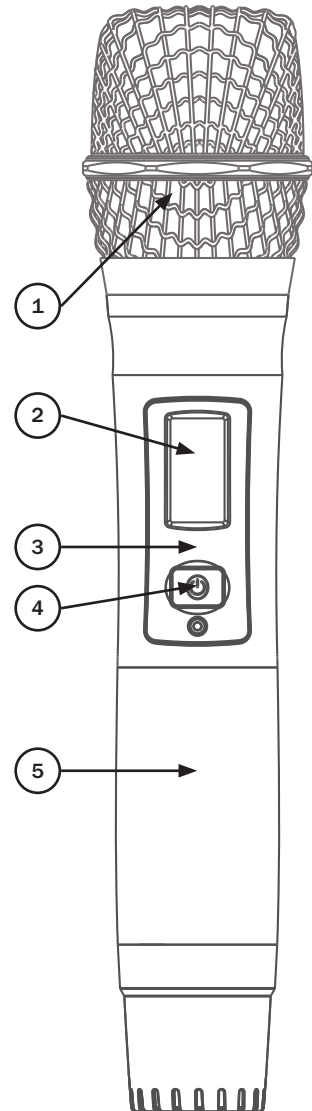

## Beltpack transmitter identification:

1. Microphone Input
2. Volume Control
3. On / Off Switch
4. Power Indicator (illuminates when battery is low and requires changing)
5. Antenna
6. LCD Display
7. IR Transceiver
8. Battery compartment (care should be taken to observe battery polarity)
9. Battery cover

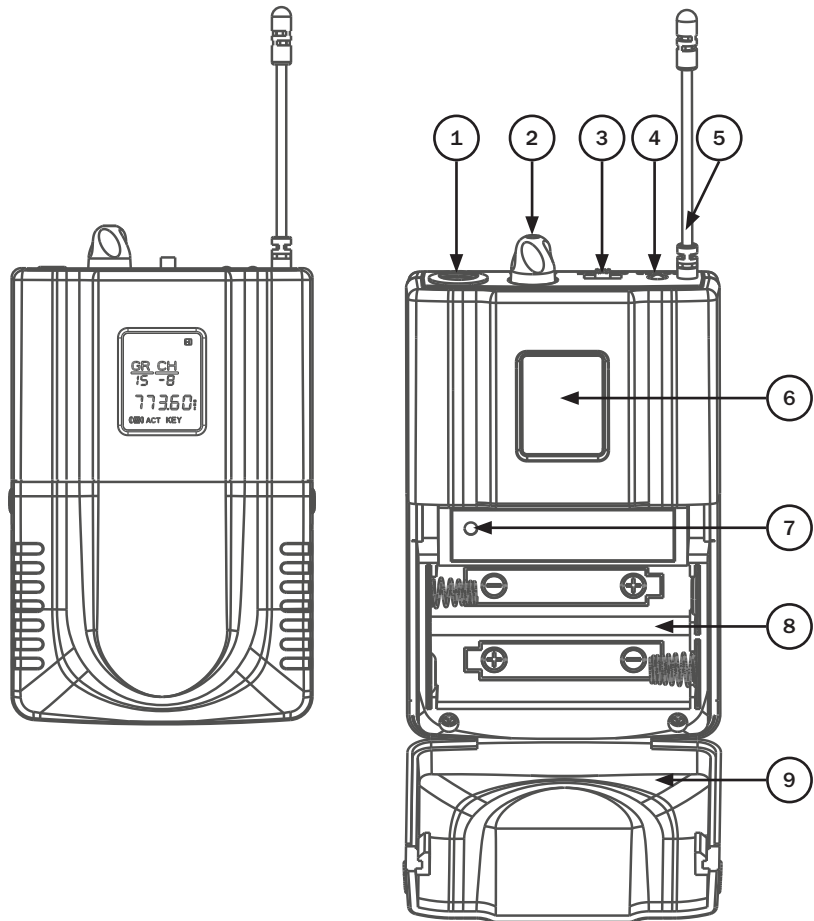

## Troubleshooting:

Problem	Possible cause	Solution
Receiver - no sound	Power button is in the OFF position. DC power adapter is not plugged in	Turn on the power button plug in the power adapter
Receiver - no LED		
Microphone - no sound but LED indicators are lit	Mic transmitter is out of range. Mic is switched off. Mic volume is turned down. Batteries in mic are not installed properly. Receiver is not connected to an amp or mixer.	Ensure that the mic is within range. Turn on the mic switch. Turn up the mic volume on the receiver. Reinstall or use new batteries. Connect an output cable to an amp or mixer
Distorted sound or feedback	The 4 mics may be too close together. Batteries are running out of charge. Mic volume may be too high. Possible interference from another source.	Increase the distance between mics. Replace the batteries. Reduce the volume. Move the system away from other electric sources.

### **NOTE:**

The DTM 600/800 system is shipped with two handheld transmitters. The receiver in this system features a dual channel receiver allowing both handheld microphones to be used simultaneously, an additional belt pack kit maybe purchased if required to be used in place of the handheld transmitters. Each receiver channel in this system may only be used with one transmitter at any one time. If the user attempts to power on, and use two transmitters with one receiver the system will malfunction and not operate correctly as one transmitter will cut out the RF Radio signal to the second transmitter.

Available in two frequency ranges, the DTM800 series is for use in the 863-865Mhz CH70 band license free while the DTM600 series is for use in the 606-614Mhz CH38 band. To operate microphones in the 606-614Mhz CH38 band the user must obtain a license from the relevant authorities before using the product.

## **Optional DTM Series Add On Beltpack Kits**

Belt pack transmitter plus headset and lavalier microphones to be used in place of the handheld transmitter.

Specifications	DTM 800BP	DTM 600BP
Operating frequency	863.0Mhz-865.0Mhz	606.0Mhz-614.0Mhz
Battery type	2 x 1.5V AA (not supplied)	
Order code	MIC71	MIC73



***Correct Disposal of this Product  
(Waste Electrical & Electronic Equipment)***

**(Applicable in the European Union and other European countries  
with separate collection systems)**

This marking shown on the product or its literature, indicates that it should not be disposed of with other household wastes at the end of its working life. To prevent possible harm to the environment or human health from uncontrolled waste disposal, please separate this from other types of wastes and recycle it responsibly to promote the sustainable reuse of material resources.

Household users should contact either the retailer where they purchased this product, or their local government office, for details of where and how they can take this item for environmentally safe recycling.

Business users should contact their supplier and check the terms and conditions of the purchase contract. This product should not be mixed with other commercial wastes for disposal.

