



I-75

RELAY ACTIVATED BY FREQUENCY. (2 - 15 KHz.).

The I-75 is a relays automatism activated for frequency. According to the frequency selected by the user, when this one is detected by the module, the output will be activated.

The adjustment of the detection frequency is done through the potentiometer inserted in the circuit.

It includes output to place an exterior potentiometer, protection against polarity inversion, operating led indicator and terminals for its connection.

TECHNICAL CHARACTERISTICS.

Voltage.....	12 V. C.C.
Minimum Consumption.....	10 mA.
Maximum Consumption.....	75 mA.
Min, Input Voltage.....	100 mV.
Max, Input Voltage.....	3V.
Detection Frequency margin.....	from 2 to 15 KHz.
Detection Frequency Max Deviation.....	± 150 Hz
Max. output load per relay.....	3 A.
Protection against polarity inversion.....	Yes.
Dimensions.....	70 x 45 x 30 mm.

OPERATING MODE.

POWER SUPPLY. The I-75 circuit had to be supplied by a 12 VDC power supply correctly filtered. We recommend you to use the FE-2 power supply, which has been developed to perfectly answer to the circuit needs, or a 12V battery for mobile applications.

Install a fuse and a switch has it is indicated on the schedule. Both are necessary for the module's protection as well as for your own safety, as it is required by the "CE" regulations.

Connect the positive and the negative of the power supply to the respective positive and negative terminals of the module, indicated in the wiring map. The distance between the power supply and the module has to be as short as possible. Verify that the assembly is correct.

ADJUSTMENT OF THE DETECTION FREQUENCY. Connect the input of frequency that you wants to control to the terminal indicated in the drawing. The injected signal will not be lower than 100 mV. neither superior to 3 V. You have to use shielded cable and to connect the braid to the ground. Once the connection done, you can supply to the module the exact frequency that it has to automatically detect later. Then, you have to adjust the "Detection Frequency Adjustment" potentiometer till the led and the output relay are connected.

During the adjustment of the detection frequency it is normal that the relay "make noise" (it is because you are moving around this frequency). Then, you have to adjust the potentiometer of the circuit with the higher sensitive possible till this effect (noise) disappears and the relay will be correctly connected.

If this adjustment is too difficult, and you wish a higher potentiometer's sensitivity, you can substitute it by an other with the same value but "multi round" type.

OPERATING MODE. Once the detection frequency adjusted, you can supply the module. Each time you will activate the switch to allow the current pass, the relay do a fast and momentary connection to indicate is activation. This function is an intrinsic function and it cannot be eliminated.

Later, the module, in permanent stand by state will remain prepared to filter any frequency received on the input; and only connecting the output when it will received the same frequency than the adjusted one.

OUTPUT CONNECTION. LOAD. The I-75 output is controlled by a relay, and accepts any device up to 5 A. The relay is not a component supplying voltage but its function is limited to accept or deny the voltage passage like a standard switch. For this reason, you have to supply the load through this component.

The relay has three output terminals: The normally open quiescent (NO), the normally closed quiescent (NC) and the common. Install it between the Common and the NO. For the inverse function you have to place the load between the NC and Common. On the drawing "Output Connection. Load" you can see how to make 12V DC and 230 V AC Connections.



GENERAL WIRING MAP.

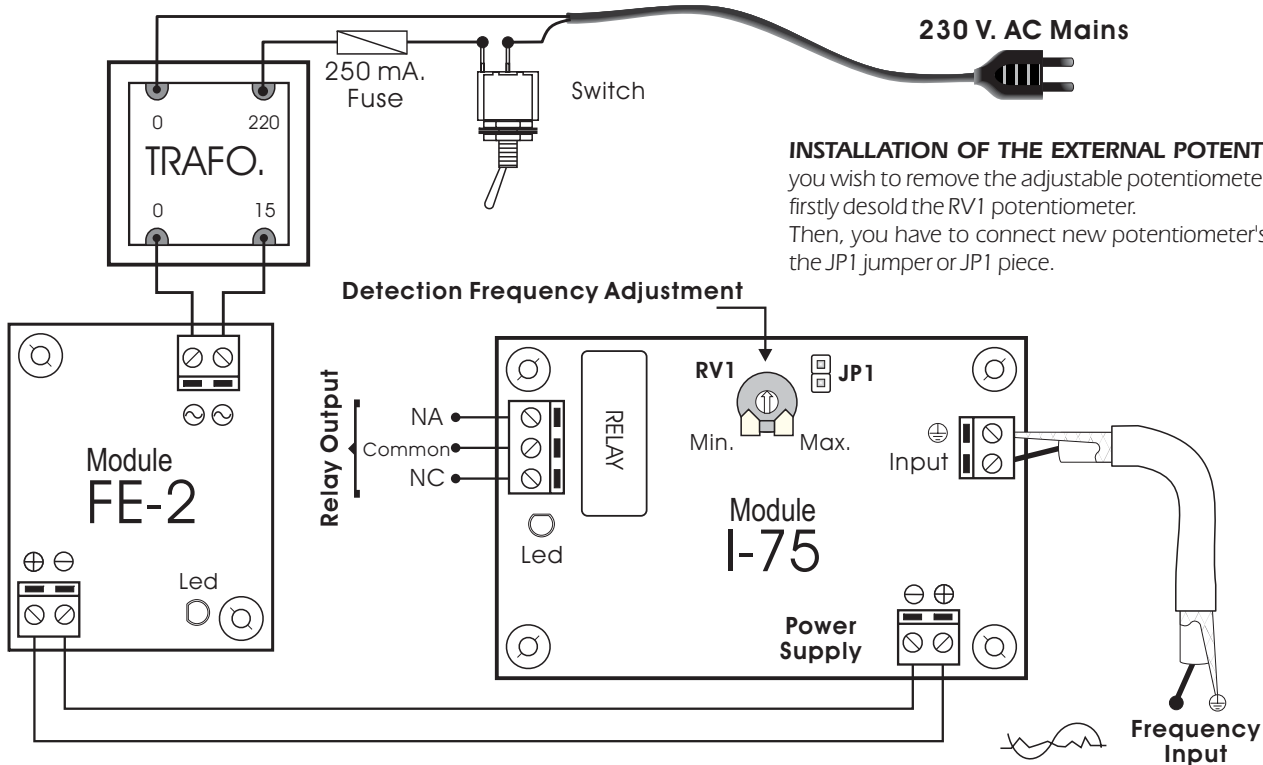

INSTALLATION OF THE EXTERNAL POTENTIOMETER. If you wish to remove the adjustable potentiometer, you have to firstly desold the RV1 potentiometer. Then, you have to connect new potentiometer's terminals to the JP1 jumper or JP1 piece.

HOW TO CONNECT THE LOAD.

12 V DC CONNECTION

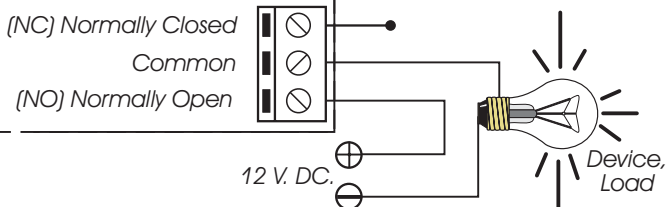

230 V AC CONNECTION

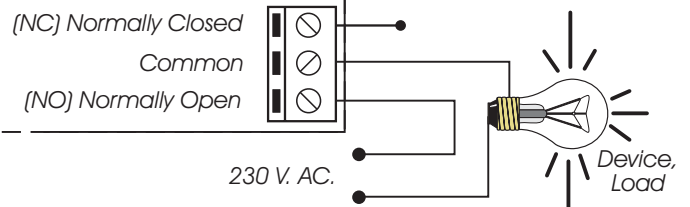

INFORMATION ABOUT THE OUTPUT. During the operating mode and according to its load, it could happen a fluctuation or an incorrect working of the output. In such case, you have to install an anti-spark circuit between both contacts of the relay used in this connection, as it is indicated on the drawing.

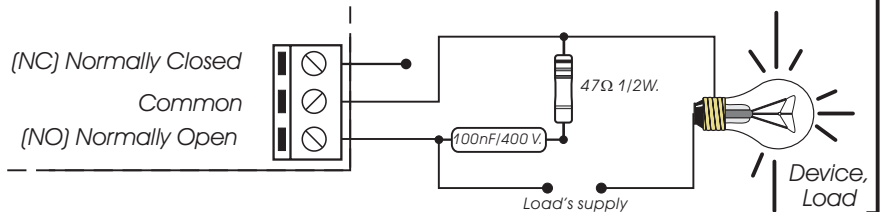

TECHNICAL SUPPORT AND INFORMATION.

For any questions or more information:

By Fax. (24h.) +34.93.432.29.95 **By Mail:** C/ Quetzal, 17-21, Entlo. 2º (08014) BARCELONA - SPAIN.

By E-Mail: sat@cebek.com

Keep you invoice. For any repairing could you send this with module. Else, the module will lost the warranty.

All the module's CEBEK have **3 years of total warranty** in technical repairing, and spares from the date of buy.

CEBEK is trade make of FADISEL S.L. more than 300 module's are available in stock for any purpose **request our CATALOGUE**, or visit our Web site

www.cebek.com

MORE 300 MODULES.

WARRANTY
3 YEARS