

57mm 7-SEGMENT DIGITAL CLOCK

Large 57mm clock & temperature display
with extra unique feature

Total solder points: 263

Difficulty level: *beginner* 1 2 3 4 5 *advanced*

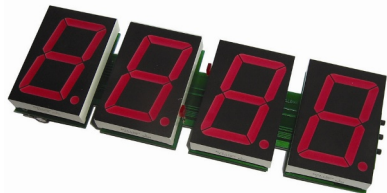

K8089



VELLEMAN NV
Legen Heirweg 33
9890 Gavere
Belgium Europe
www.velleman.be
www.velleman-kit.com

Features :

- ☑ 12/24h clock system
- ☑ min temp readout:
 - celsius: -20°C
 - fahrenheit: -4°F
- ☑ max temp readout:
 - celsius: 70°C
 - fahrenheit: 158°F
- ☑ auto toggle function
- ☑ easy time setting
- ☑ easy wall mounting
- ☑ back-up battery
- ☑ automatic frequency detection
- ☑ unique extra feature: auto toggle between time/temp and scrolling sign 'OPEN' or 'CLOSED'

Specifications



- power supply: 12VAC (e.g. PS1205AC)
- power consumption: 250mA max. (incl. temp. sensor*)
- backup battery: 3V (CR2032)
- power consumption on backup battery: +/-1mA
- dimensions: 230x74x32mm / 9 x 2.9 x 1.25"

* **optional** : temperature sensor K8067 or VM132

1. Assembly (Skipping this can lead to troubles !)

Ok, so we have your attention. These hints will help you to make this project successful. Read them carefully.

1.1 Make sure you have the right tools:

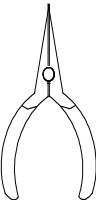
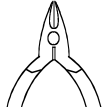
- A good quality soldering iron (25-40W) with a small tip.  apply
- Wipe it often on a wet sponge or cloth, to keep it clean; then solder to the tip, to give it a wet look. This is called 'thinning' and will protect the tip, and enables you to make good connections. When solder rolls off the tip, it needs cleaning.
- Thin raisin-core solder. Do not use any flux or grease. 
- A diagonal cutter to trim excess wires. To avoid injury when cutting excess leads, hold the lead so they cannot fly towards the eyes.
- Needle nose pliers, for bending leads, or to hold components in place.  
- Small blade and Phillips screwdrivers. A basic range is fine.

For some projects, a basic multi-meter is required, or might be handy



1.2 Assembly Hints :

- ⇒ Make sure the skill level matches your experience, to avoid disappointments.
- ⇒ Follow the instructions carefully. Read and understand the entire step before you perform each operation.
- ⇒ Perform the assembly in the correct order as stated in this manual
- ⇒ Position all parts on the PCB (Printed Circuit Board) as shown on the drawings.
- ⇒ Values on the circuit diagram are subject to changes.
- ⇒ Values in this assembly guide are correct*
- ⇒ Use the check-boxes to mark your progress.
- ⇒ Please read the included information on safety and customer service

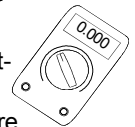

1.3 Soldering Hints :

1- Mount the component against the PCB surface and carefully solder the leads

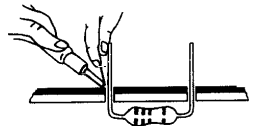

2- Make sure the solder joints are cone-shaped and shiny

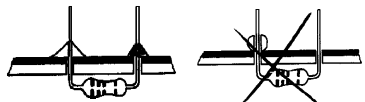

3- Trim excess leads as close as possible to the solder joint

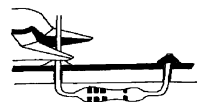

Included in
this kit

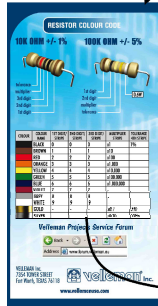

2. RESISTOR

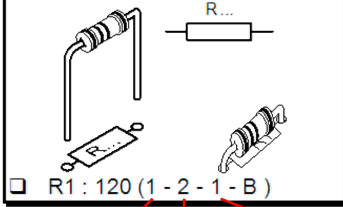

| COLOUR | COLOUR NAME | 1ST DIGIT/ STRIPE | 2ND DIGIT/ STRIPE | 3RD DIGIT/ STRIPE | MULTIPLIER STRIPE | TOLERANCE 4TH! |
|--------|-------------|-------------------|-------------------|-------------------|-------------------|----------------|
| Black | BLACK | 0 | 0 | 0 | x1 | 1% |
| Brown | BROWN | 1 | 1 | 1 | x10 | |
| Red | RED | 2 | 2 | 2 | x100 | |
| Orange | ORANGE | 3 | 3 | 3 | x1.000 | |
| Yellow | YELLOW | 4 | 4 | 4 | x10.000 | |
| Green | GREEN | 5 | 5 | 5 | x100.000 | |
| Blue | BLUE | 6 | 6 | 6 | x1.000.000 | |

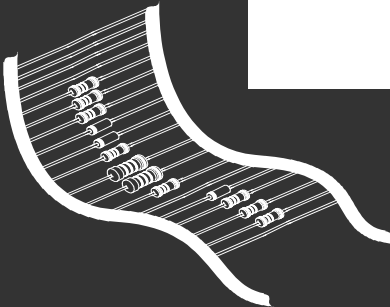

REMOVE THEM FROM THE TAPE ONE AT A TIME !

**DO NOT BLINDLY FOLLOW THE ORDER OF THE COMPONENTS ONTO THE TAPE.
ALWAYS CHECK THEIR VALUE ON THE PARTS LIST!**

Hint: if you want to mount the clock against a wall, you can use the unstuffed PCB as a template to mark the drill holes.

1. Resistors.

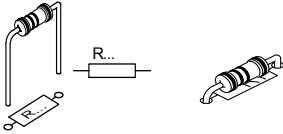

Hint: resistors can be soldered at component side of the board.

- R1 : 100K (1 - 0 - 4 - B)
- R2 : 10 (1 - 0 - 0 - B)
- R3 : 22K (2 - 2 - 3 - B)
- R4 : 22K (2 - 2 - 3 - B)
- R5 : 240 (2 - 4 - 0 - 0 - 1)
- R6 ... R37 : 220 (2 - 2 - 1 - B) !
- R38: 1K (1 - 0 - 2 - B)
- R39 ... R42 : 10K (1 - 0 - 3 - B) !
- R44: 220 (2 - 2 - 1 - B)
- R45: 2K2 (2 - 2 - 2 - B)
- R46: 10K (1 - 0 - 3 - B)

2. Diodes (check the polarity)

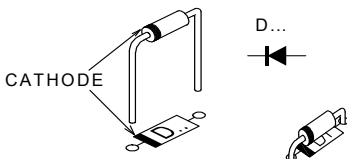

- D1 : 1N4007
- D2 : 1N4007
- D3 : 1N4007
- D4 : 1N4007
- D5 : BAT85
- D6 : BAT85
- D7 : 1N4148

3. Zener diodes (check the polarity)

- ZD1 : 4V3
- ZD2 : 4V3
- ZD2 : 4V3
- ZD3 : 4V3

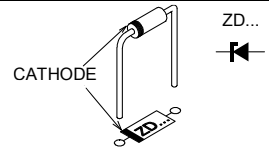

4. IC sockets. Watch the position of the notch!

- IC1 : 14p
- IC2 : 16p
- IC3 : 16p
- IC4 : 16p
- IC5 : 16p

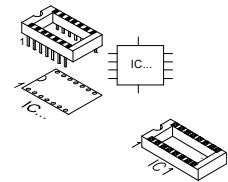

5. Capacitors

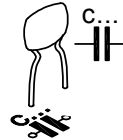

- C1 ... C11 : 100nF (104)
- C13 : 100nF (104)

6. Switches

Hint: mount a screw connector if remote selection is needed, see step 12.

- SW1 : Open / closed

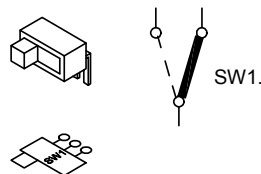

7. Transistors

- T1 : BC547
- T2 : BC547

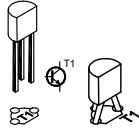

8. Voltage regulator

- VR1: UA7808

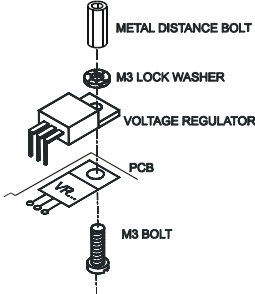

- VR2: UA78L05

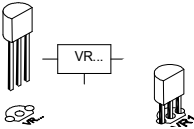

9. Battery holder

- E1 : CR2032 (3V)

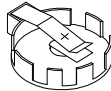

10. Push buttons

- SW2 : Sign on/off
- SW3 : Hours +
- SW4 : Minutes +



11. Pinheaders

2pins:

- SK3 : 12h/24h
- SK4 : °C/°F
- SK5 : Clock/clock+temp

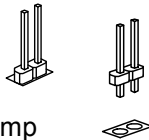

3pins:

- hh:mm / hh.mm

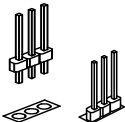

12. Terminal blocks

- SK1 : 2p power 12VAC
- SK2 : 3p Temp. sensor

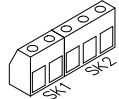

! If remote selection is needed :

- SW1 : 2p Open/closed

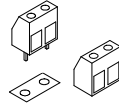

13. Electrolytic capacitor. Watch the polarity !

- C12 : 470µF / 25V

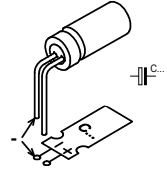

14. Heat sink

Make sure that the heat sink does not touch C12 !

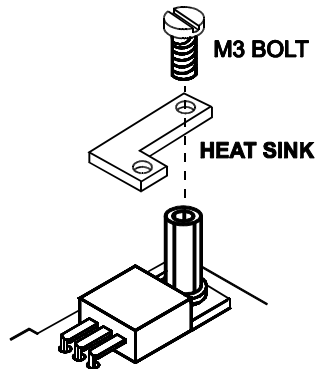

15. IC's. Watch the position of the notch!

- IC1 : VK8089
(programmed PIC16F630-I/P)
- IC2 : 74HC595
- IC3 : 74HC595
- IC4 : 74HC595
- IC5 : 74HC595

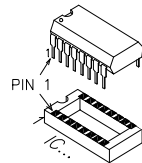

MOUNT THESE COMPONENTS ON THE PCB SOLDERSIDE, SOLDER THEM ON THE COMPONENTS SIDE

1. Tulip pin headers

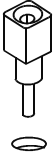

- DY1 : 2 x 5pins
- DY2 : 2 x 5pins
- DY3 : 2 x 5pins
- DY4 : 2 x 5pins

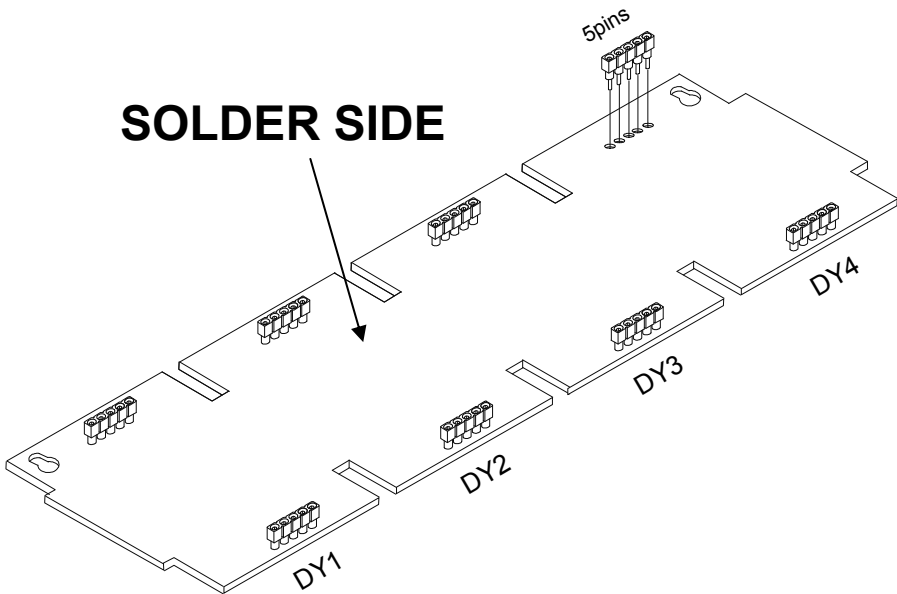
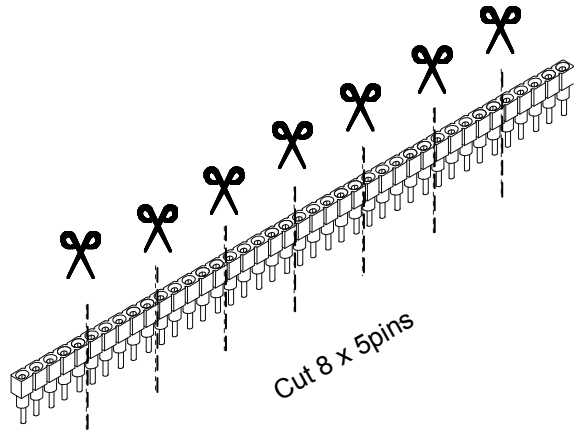

2. Digit displays

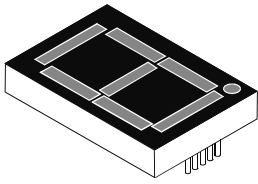

- DY1
- DY2
- DY3
- DY4

ATTENTION: mount the displays so that the dot is mounted towards the push button.

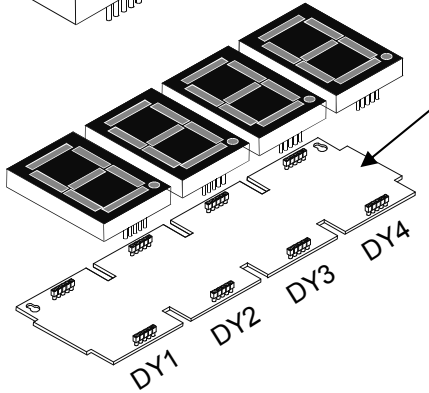

Side with push buttons

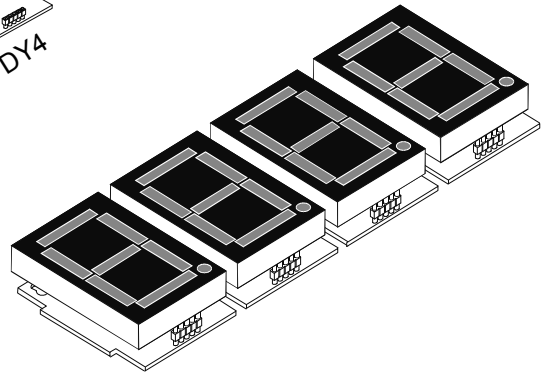

Make sure that all displays are correctly mounted !

3. Assembly of the enclosure

1 Mount the leds, watch the polarity.

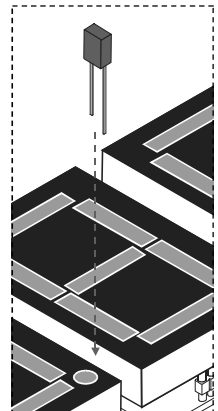
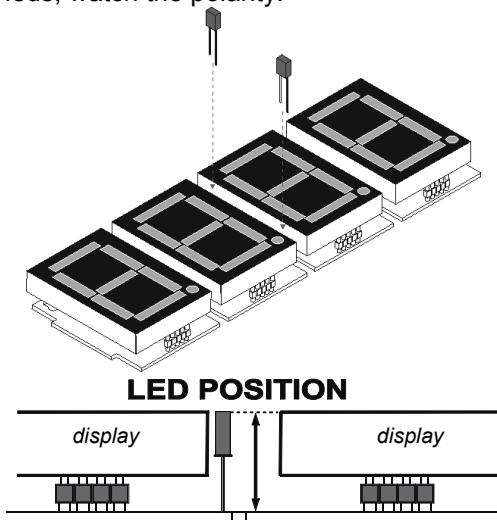
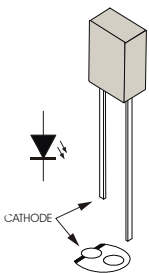

4. Test and connection

1. Power supply:

Supply 9-12VAC to the inputs marked '12VAC'.

- ☞ Make sure supply can deliver 300mA
- ☞ Make sure to use an AC power supply. If you supply a DC voltage, the accuracy of the clock will be 5% worst case.

2. Back-up battery:

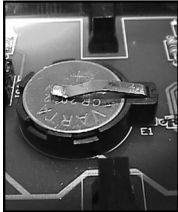

Insert a 3V CR2032 battery in the battery holder. If power fails, unit will retain the clock. Display will remain blank.

☞ **Note:** Accuracy when running on backup battery: 5% worst case. Consumption: +/- 1mA

☞ **CHECK IF THE CLOCK IS WORKING CORRECTLY (see page 13)**

5. Optional temperature sensor

If you have ordered an additional temperature sensor K8067 or VM132 then you can let the temperature automatic toggle with the time and sign.

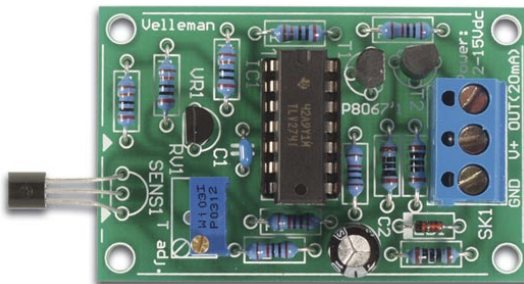

Optional temperature sensor

Connect the terminals marked GND, V+ and IN to the corresponding terminals of the temperature sensor. As this is a current loop sensor, you can run several meters of wire between the sensor and the clock.

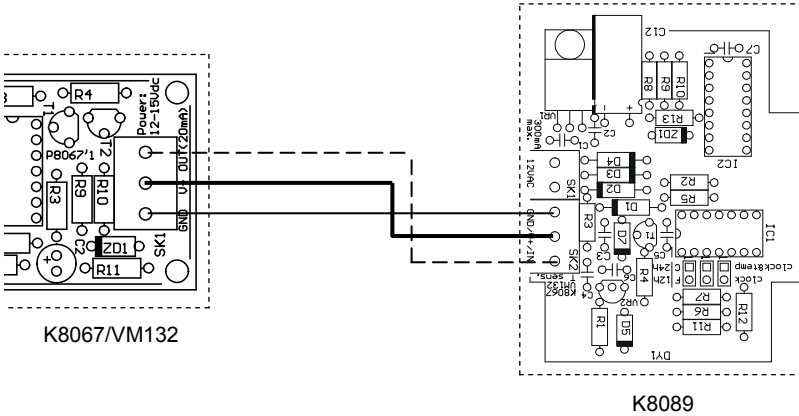

Adjusting the temperature sensor (Skip this if there is no temp. sensor connected. In this case, make sure jumper is set to 'clock').

Put a reliable thermometer next to the temperature sensor and leave it there for a while. Press and hold 'Min'-button and apply power to the unit. The unit will display the temperature only (Make sure back-up battery is removed) Adjust the multiturn pot. (RV1) on the temperature sensor until the displayed temperature matches the temperature indicated by the thermometer. Remove and re-apply power to restart the clock. If necessary, insert backup battery.

6. Jumper settings

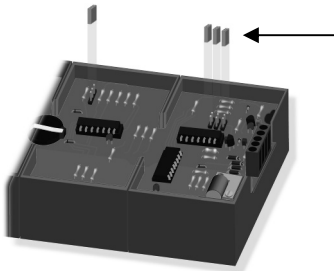

Use the shunt to select for choosing the display, temperature en time readout.

| Mode | Jumper placed | Jumper removed |
|----------------|---------------|---------------------|
| Display | clock | clock / temperature |
| Temp | °F | °C |
| Time | 12h | 24h |

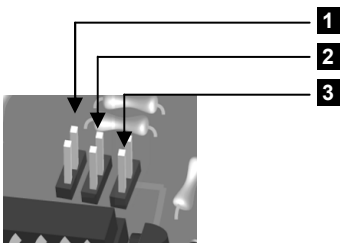

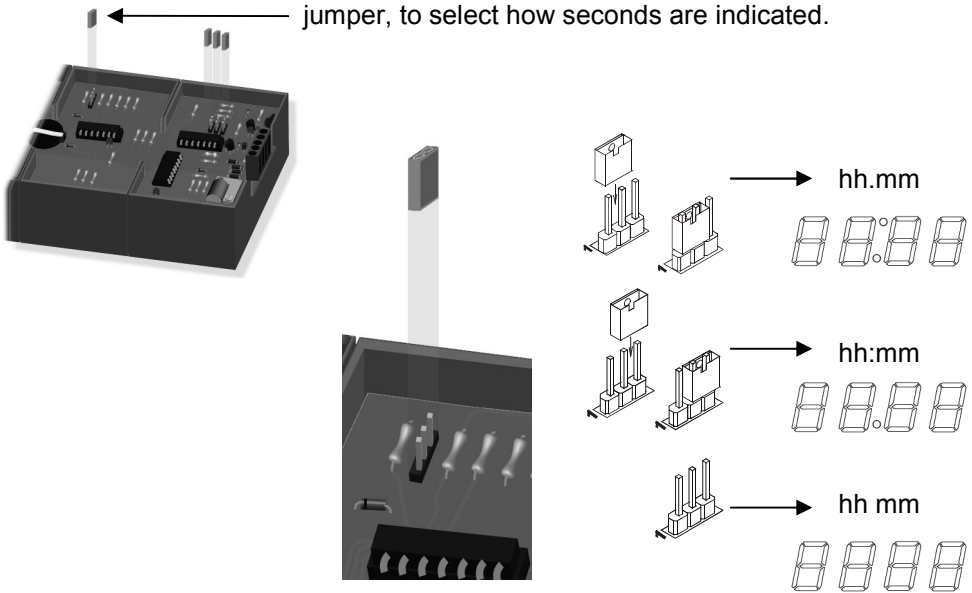

7. Assembly in enclosure

1 Assemble the 4 individual housing together.

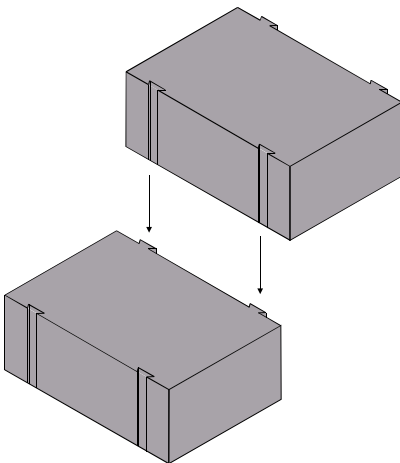

2 Turn the PCB around with the displays on top, place the enclosure on the PCB.

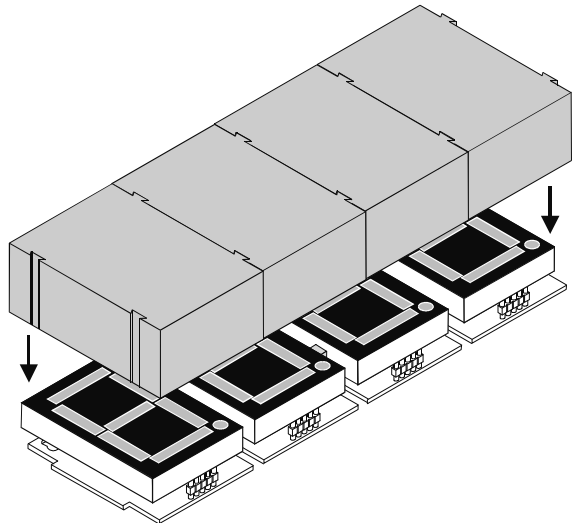

8. Use

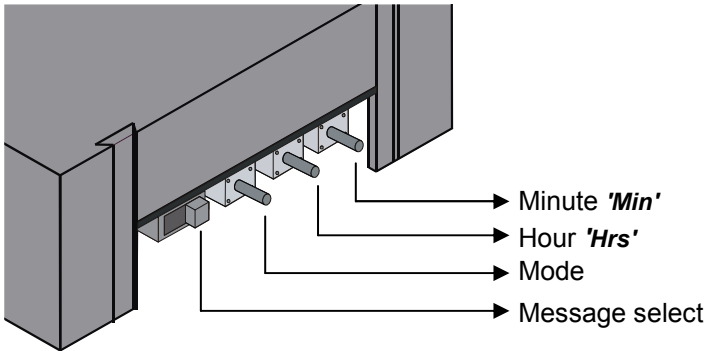

1. Use as thermometer only (no clock):



Hold 'Min'-button and apply power. Unit will display temperature only. If required, you can permanently bridge the 'Min'-button.

2. Setting the time:



Select 12h or 24h readout by means of the jumper. Press 'Hrs' to set the hours, press 'Min' to set minutes. At release, seconds will start from zero.

3. Turning on/off the 'OPEN'/'CLOSED' display.



Press 'Mode' to toggle between 'ON' (show sign) and 'OFF' (do not show sign).

Selecting 'OPEN'/'CLOSED'. The slide switch allows you to display either 'OPEN' or 'CLOSED'. You can remove the slide switch and replace it by the supplied screw connector.

By doing so you can easily put an optional switch in a remote location, to select between 'OPEN' or 'CLOSED'.

4. Extra feature:

Hold 'Hrs'-button and apply power (make sure to remove backup battery first). Now, the unit displays the approx. AC grid frequency. If required, you can permanently bridge the 'Hrs'-button.

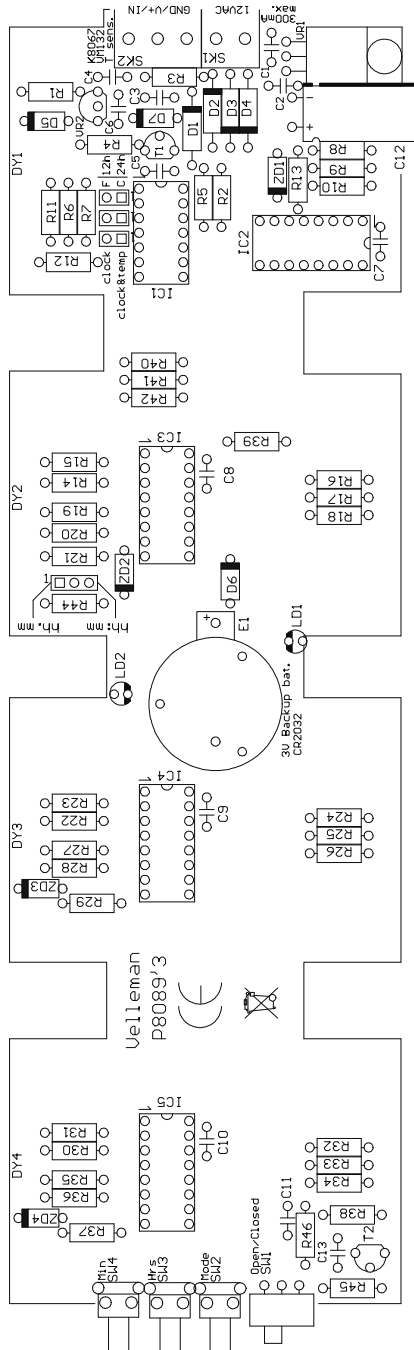

Schematic diagram

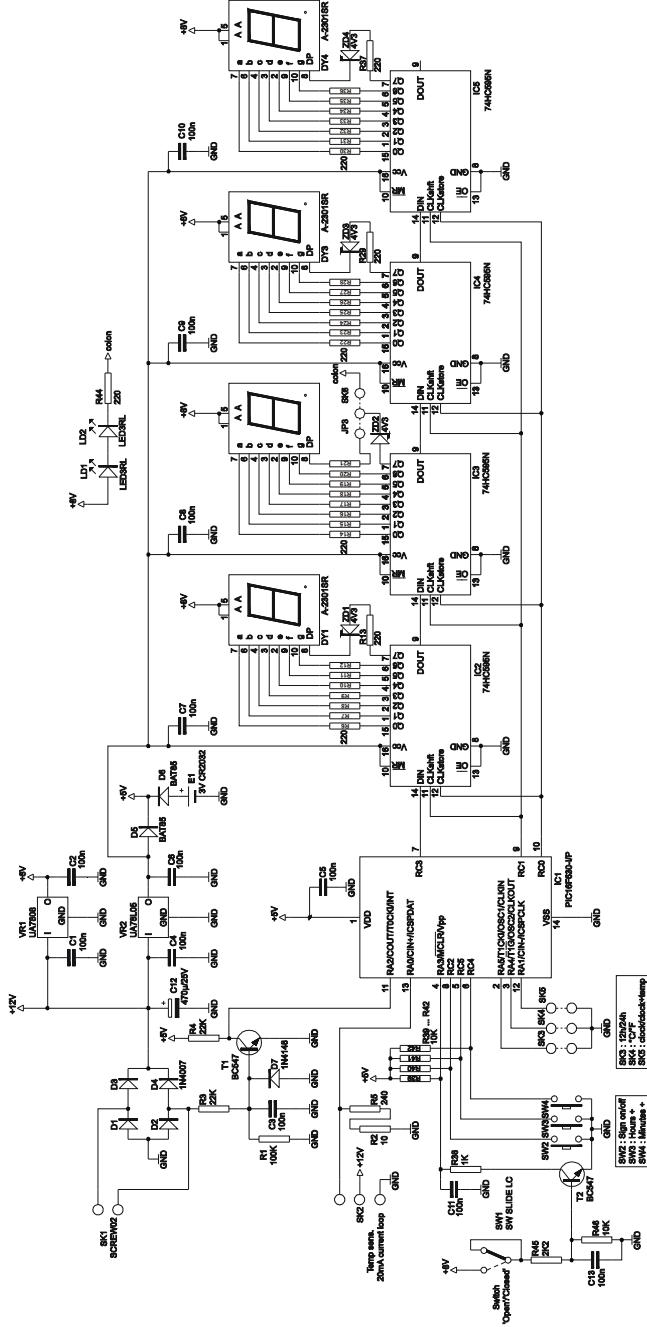

EDU 01

SOLDERLESS EDUCATIVE STARTERBOX



The EDU01 basic experiment kit is the first step into the world of modern electronics. Build your own circuits in a fun, safe and educative way.



EDU 02

SOLAR ENERGY EXPERIMENT KIT



Fun solar powered projects. Learn all about solar energy.

EDU 03

SOLDER EDUCATIVE STARTER BOX



Learn how to solder, build different exciting projects. Includes spare components and demo boards.



EDU 05

USB TUTOR BOARD

Learn how to connect your computer with the outside world, master the USB communication with tutorial examples. Play with LED indicators and learn how to drive LCDs displays.



EDU 06

SCOPE EDUKIT



This board with different signals will teach you how to use an oscilloscope. Optimized instructions for use of our HPS140 oscilloscope. YouTube demo movies.



EDU 10

PIC™ TUTOR KIT



Enter the world of microcontroller programming, easy step by step instructions. Includes programmer and test board.

**COMING
SOON**

