



TL-26

1 CHANNEL R.F RECEIVER for TRANSMITTERS TL-20/21 and TL-28



The TL-26 module, decode signals sent by CEBEK transmitters TL-20, TL-21 and TL-28 with which it is only compatible, and connect the corresponding output.
It allows to configure each output as standard or Flip-Flop mode.
It includes micro-switches to select the code, Indicator Leds and an Output for an extension.

TECHNICAL CHARACTERISTICS.

| | |
|--|--------------------------|
| Voltage |12 V. D.C. |
| Minimum/Maximum Consumption |2 mA / 65 mA. |
| Security Code combinations |13.122. |
| Operating Frequency |433.92 MHz. |
| Antenna Length |130 mm. |
| Max. Output Load by relay |5 A. |
| Protection against inversion of polarity, (P.I.P.) |Yes. |
| Sizes |98,75 x 96 x 30 mm. |

INSTALLATION and OPERATING MODE.

POWER SUPPLY. The TL-26 circuit had to be supplied by a 12 VDC power supply correctly filtered. We recommend you to use the FE-103 power supply, which has been developed to perfectly answer to the circuit needs.

Install a fuse and a switch has it is indicated on the schedule. Both are necessary for the module's protection as well as for your own safety, as it is required by the "CE" regulations.
Connect the positive and the negative of the power supply to the respective positive and negative terminals of the module TL-26, indicated in the wiring map. The distance between the power supply and the module has to be as short as possible.
Verify that the assembly is correct.

ANTENNA INSTALLATION. The module requires an antenna to receive the signal sent by the transmitter. You can use a telescopic antenna like the antenna used for radio receivers (our accessory Ref. C-0509) or any other metallic bar. Nevertheless, the exact length of this antenna has to be 130 mm.
The antenna cable has to be inferior to 25 cm, it has to be shielded, and if you have a ground contact or a negative, the braid of the cable has to be connected to the antenna input indicated with the ground symbol. See the paragraph "General Wiring Map".

OUTPUT CONNECTION. LOAD. The TL-26 module output is controlled by a relay, and accepts any device up to 5 A. The relay is not a component supplying voltage but its function is limited to accept or deny the voltage passage like a standard switch. For this reason, you have to supply the load through this component.
The relay has three output terminals: The normally open quiescent (NO), the normally closed quiescent (NC) and the common. Install it between the Common and the NO in accordance with the schedule Fig.1. For the inverse function you have to place the load between the NC and Common.

Fig. 1. Load Connection.

12 V DC CONNECTION.

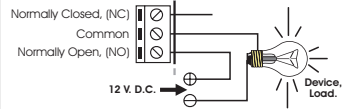

230 V AC CONNECTION.

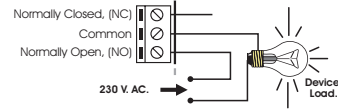

INFORMATION ABOUT THE OUTPUT. During the operating mode and according to its load, it could happens fluctuation or an incorrect working of the output. In such case, you have to install an anti-spark circuit (100 nF/400V Type X2 Capacitor and 47W, 1/2 W resistor) between both contacts of the used relay, as it is indicated on the drawing.

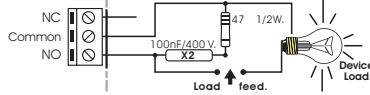

OPERATING MODE.

Each output has a dips switches, indicated as SET-A for the output N°1 and as SET-B for the output N°2. Thanks to these dips you can configure each output in mode monostable or latching.
If you place the switch N°1 in ON position and the switch N°2 in OFF position, the corresponding output will operate in Monostable mode. At the opposite, if you place the switch 1 in OFF position, and the switch 2 in ON, the output will operate in Latching mode.
Do not forget that both switches can't be in ON or OFF position at the same time, otherwise the module doesn't correctly operate.

EXTENSION OF THE SYSTEM.

The TL-26 module accepts an extension composed by 4 supplementary outputs in order to become a eight outputs receiver. You can indistinctly use the TL-24 module, extension composed by 4 monostable outputs (standard) or the TL-25 module, extension composed by 4 latching outputs (Flip-Flop).
It is important to carefully read the instructions manual corresponding to these modules and mainly the paragraph about connections and wiring. Nevertheless, on the following drawing, you can see the

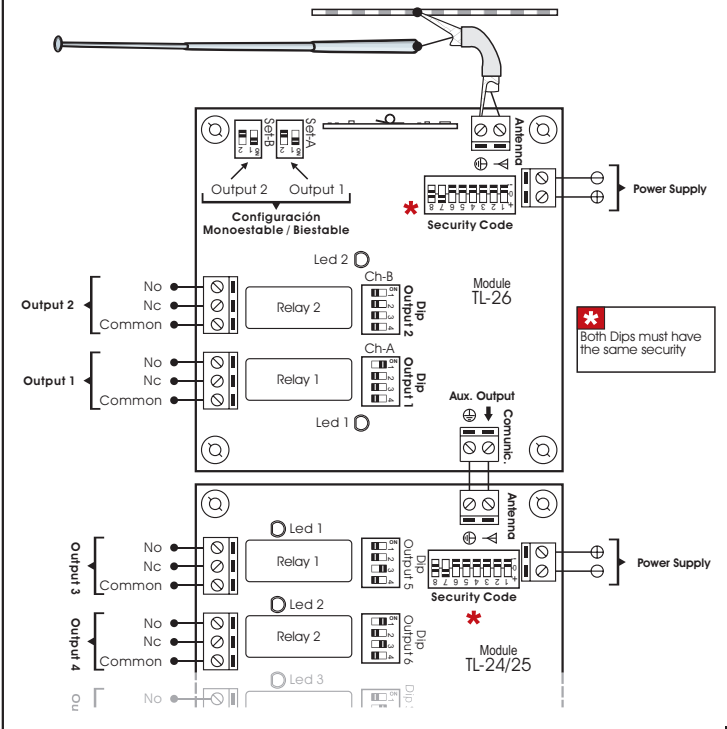

OPERATING MODE.

TO CONFIGURE THE SECURITY CODE. All CEBEK remote control modules, operate with the same homologated frequency 433.92 MHz. For this reason they have a micro-switches battery composed by 8 binary switches, to allow to configure the security code that make the difference and exclusive use of each module.

The security code will allow you to personalise your receiver and it has to be the same than the used for the transmitter, otherwise you can't establish a communication between both modules.
Each switch composing the mentioned battery can be placed in three different positions "-", "0" and "+". You have to change the initial code (code supplied from factory) modifying switches and selecting your private security code. You can choose among 13.122 different combinations.

TO ASSIGN THE CHANNEL NUMBER. Independently of the security code, for each channel or output, you have to assign which button of the transmitter will control this output.
On the instructions manual of TL-20, TL-21 and TL-28 transmitters, each push button is identified with a

The selection of the number on the corresponding battery or Dip that you wish to configure will be done in binary mode, using the four switches corresponding to the output to configure. If you place any of these four switches in ON position, its binary value will correspond to "1", and if you place it in OFF position its binary value is "0".
On the table Fig. 3, you can see the equivalence between decimal numbers from 0 to 8 and their respective binary codes.

Fig. 2. Binary value of switches according to their positions.

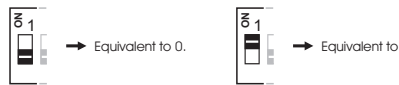

Configure each Dip with the wished button number making the corresponding binary combination. Do not establish a different combination than specified ones in the table Fig.3 otherwise you will indicate a wrong number to the module.
It is not necessary to chronologically assign the number of push buttons to each output, neither to assign a different number to each output. If you wish, you can use the same number of button for several channels, controlling therefore these different channels with a single and same button.

Fig. 3. Equivalence between Decimal & Binary.

| Switches | 1 | 2 | 3 | 4 | |
|-----------------|---|---|---|---|---|
| Button Number 1 | → | 0 | 0 | 0 | 0 |
| Button Number 2 | → | 1 | 0 | 0 | 0 |
| Button Number 3 | → | 0 | 1 | 0 | 0 |
| Button Number 4 | → | 1 | 1 | 0 | 0 |
| Button Number 5 | → | 0 | 0 | 1 | 0 |
| Button Number 6 | → | 1 | 0 | 1 | 0 |
| Button Number 7 | → | 0 | 1 | 1 | 0 |
| Button Number 8 | → | 1 | 1 | 1 | 0 |

| Switches | 1 | 2 | 3 | 4 | |
|------------------|---|---|---|---|---|
| Button Number 9 | → | 0 | 0 | 0 | 1 |
| Button Number 10 | → | 1 | 0 | 0 | 1 |
| Button Number 11 | → | 0 | 1 | 0 | 1 |
| Button Number 12 | → | 1 | 1 | 0 | 1 |
| Button Number 13 | → | 0 | 0 | 1 | 1 |
| Button Number 14 | → | 1 | 0 | 1 | 1 |
| Button Number 15 | → | 0 | 1 | 1 | 1 |
| Button Number 16 | → | 1 | 1 | 1 | 1 |

(*). Only if you use the TL-21 Transmitter.

(**). Only if you use the TL-28 Transmitter.

OPERATING. Once the security code selected, the assignment of the push button to each output done and receiver's connections done, you can supply the module.

When you will press the push button on the transmitter, the assigned output will be activated and maintained connected during the push button is pressed, and when you release the button the assigned output will be deactivated.

Do not forget that the transmitter doesn't accept if you press several buttons at the same time. If you wish to activate several outputs, you have to proceed one by one (step by step).

GENERAL WIRING MAP.

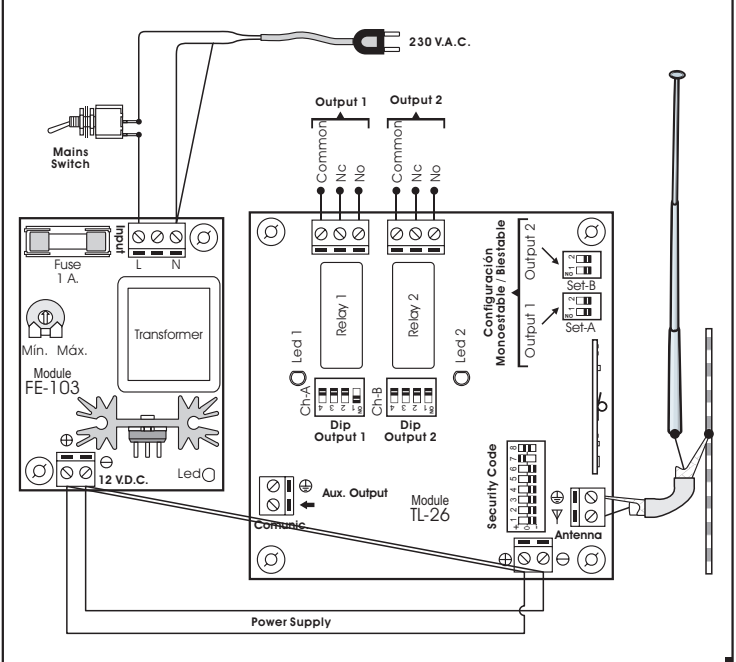

TECHNICAL CONSULTATIONS.

If you have any doubt, you could contact your wholesaler or our Technical Department.
- E-Mail, sat@cebek.com | Fax. 34.93.432.29.95 | by mail. P.O. Box. 23455 - 08080 Barcelona - Spain.
- Keep the invoice of this module. For any repair, the corresponding invoice had to be added. If the invoice is not presented together with this module, the module's warranty will be automatically cancelled.

All the module's CEBEK have 3 years of total



Much more CEBEK module's are available in our products range, please, require our general catalogue or visit our Web side. [Http://www.cebek.com](http://www.cebek.com)

